

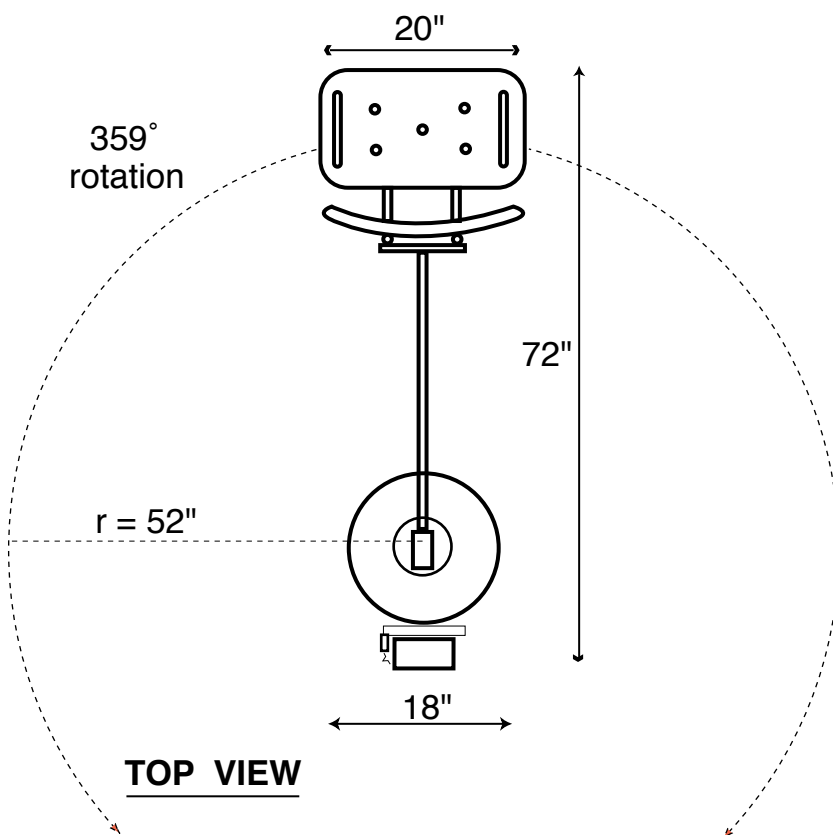

# Component Identification

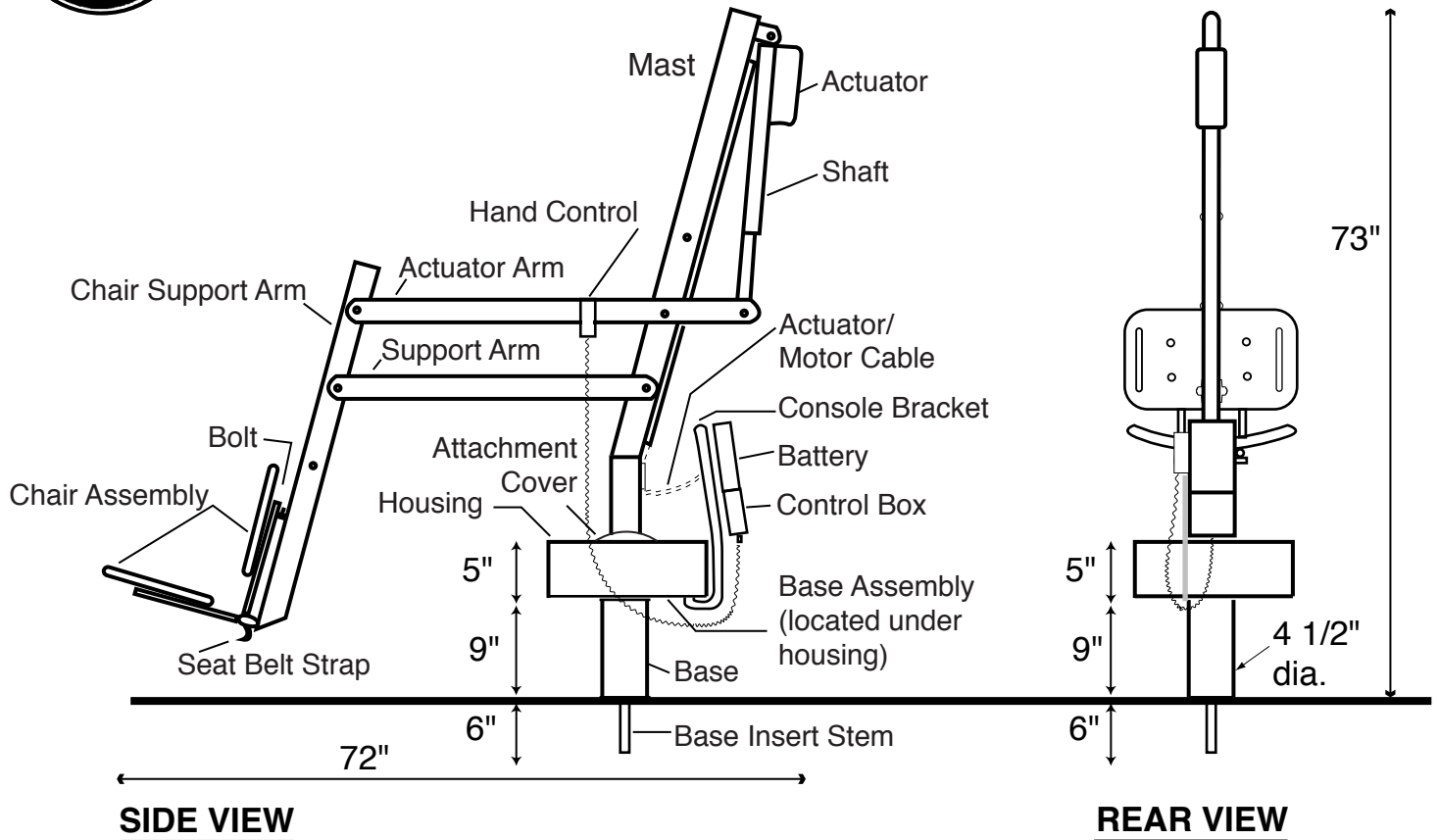

## TECHNICAL CHARACTERISTICS

- Lifting Capacity: 300 lb or 375 w/ HD
- Lifting: Linak LA32 Mechanical Actuator
- Max. Thrust: 1680 lb
- Voltage: 24 VDC
- Max. Amp: 9
- Max. Speed: 0.59 inch/sec.
- Rotation: ITT SWMK 403.033 24 VDC 13 RPM
- Gearing Ratio 9:1
- Power: Linak Rechargeable Battery Pack BAJ1
- 24 VDC, IP65 Gel Lead Acid

## MATERIALS & FINISH

- Base: Powder Coated Stainless Steel
- Housing: Powder Coating Aluminum
- Arms: Powder Coated Aluminum
- Mast: Powder Coated, Zinc Plated Steel

## DIMENSIONS

- Base dimensions: 18 inches diameter
- Total weight: 140 lb
- Overall Height: 73 in
- Overall Length (footprint): 70-76" (fully extended); 53" stored position

## RANGE OF MOTION

- Lifting:
  - Variable to suite needs of pool
  - 44" total travel with standard actuator
  - Seat Depth 18-20" below waterline
- Rotational: 359° total rotation